

# RiverSurveyor

Useful options and accessories make the RiverSurveyor a complete, turn-key solution!



**Mobile Operation:** RiverSurveyor runs on both PC and mobile phone platforms making system operation simple without any risk of losing data.



**Power/Communications:** The RiverSurveyor Power/Communications module supports both the S5 and the M9. Featuring rechargeable battery packs, it can be factory-configured with Bluetooth®, spread spectrum radio, VTG GPS, or RTK GPS.



**RTK GPS:** Available exclusively from SonTek, the optional RTK GPS solution is easy to use and offers an incredibly precise, fully integrated position solution that can augment or be an alternative to bottom tracking with moving bottom.



**Floatable Platform:** The flexible design of the S5 and M9 systems enables use either over the side of a boat, or on a small floating/tetherable platform such as the SonTek Hydroboard or the OS Trimaran.

	S5	M9
<b>SPECIFICATIONS</b>		
<u>Velocity Measurement</u>		
-Profiling Range (Distance)	0.06m to 5m	0.06m to 30m
-Profiling Range (Velocity)	+/- 20 m/s	+/- 20 m/s
-Accuracy	Up to +/- 0.25% of measured velocity; +/- 0.2cm/s <sup>1</sup>	Up to +/- 0.25% of measured velocity; +/- 0.2cm/s <sup>1</sup>
-Resolution	0.001 m/s	0.001 m/s
-Number of Cells	Up to 128	Up to 128
-Cell Size	0.02m to 0.5m	0.02m to 4m
<u>Transducer Configuration</u>	Five (5) Transducers; 4-beam 3.0 MHz Janus at 25° Slant Angle; 1.0 MHz Vertical Beam	Nine (9) Transducers; Dual 4-Beam 3.0 MHz/1.0 MHz Janus at 25° Slant Angle; 0.5 MHz Vertical Beam
<u>Depth Measurement</u>		
-Range	0.20m to 15m	0.20m to 80m
-Accuracy	1%	1%
-Resolution	0.001m	0.001m
<u>Discharge Measurement</u>		
-Range with Bottom-Track	0.3m to 5m	0.3m to 30m
-Range with RTK GPS	0.3m to 15m	0.3m to 80m
-Computations	Internal	Internal

## S5/M9 Additional Specifications

- Temperature Sensor
  - Resolution: ± 0.01° C
  - Accuracy: ± 0.1° C
- Compass/Tilt (Solid State Type)
  - Range: 360°
  - Heading Accuracy: ± 2°
  - Pitch/Roll: ± 1°
- Internal Recorder Size: 8GB
- Power/Communications
  - 12 - 18v DC
  - RS232 Communications
  - RS232 Serial GPS Input
  - Max Data Output Rate: 2 Hz
  - Internal Sampling Rate: Up to 70 Hz
- Physical/Environmental
  - Depth Rating: 50m
  - Operating Temperature: -5° to 45° C
  - Storage Temperature: -10° to 70° C

## Power Communications Module Specifications

- Batteries
  - Type: Rechargeable
  - Capacity/duration: 8 hours of continuous operation (4 hours with RTK GPS enabled)
- Telemetry Options/Range
  - Bluetooth (Phone): 60m
  - Bluetooth (Laptop): 200m
  - Spread Spectrum Radio: 2000m
- GPS Options
  - GGA / VTG Accuracy: 1m
  - RTK Accuracy: 0.03m

## Floating Platform Options

- SonTek Hydroboard
- OS Trimaran

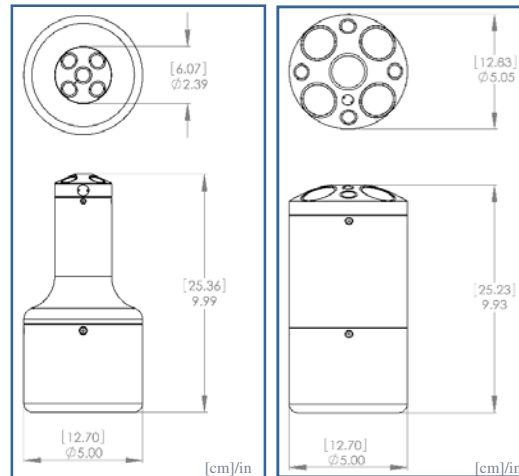

## RiverSurveyor-S5

- Weight in Air: 1.1 kg (2.5 lb)
- Weight in Water: -0.3 kg (-0.7 lb)

## RiverSurveyor-M9

- Weight in Air: 2.3 kg (5.0 lb)
- Weight in Water: -0.6 kg (-1.3 lb)



SonTek/YSI  
9940 Summers Ridge Road  
San Diego, CA 92121, USA  
Tel: +1 (858) 546-8327  
Fax: +1 (858) 546-8150  
Email: inquiry@sontek.com

[sontek.com](http://sontek.com)  
[riversurveyor.com](http://riversurveyor.com)

SonTek/YSI, founded in 1992 and advancing environmental science in over 100 countries, manufactures affordable, reliable acoustic Doppler instruments for water velocity measurement in oceans, rivers, lakes, harbors, estuaries, and laboratories. SonTek/YSI is an employee-owned company.

SonTek and RiverSurveyor are trademarks of YSI Inc., Yellow Springs, OH, USA. The RiverSurveyor is made in the USA. Lit. code S05-01-1008. November 2008. Specifications are subject to change without notice.

<sup>1</sup>Please contact SonTek/YSI for accuracies better than 1%.

# RiverSurveyor®

## Instant Discharge Measurements



# RiverSurveyor<sup>®</sup>

## Instant Discharge Measurements

Taken to Incredible Extremes.



It's an immense goal - to build a river discharge measurement system without the traditional limitations. It had to be small, portable and so easy to use that anyone could make a measurement. It had to be so robust that it could be used just about anywhere in the world under extreme conditions. The results had to be immediately recognizable. Conceived to advance measurement practices, the **RiverSurveyor S5 and M9** systems give a whole new perspective to the notion of open channel hydraulic measurements.

It's a SonTek exclusive - multiple acoustic frequencies fused with precise bandwidth control make for the most robust and continuous shallow-to-deep measurements ever. A deterministic microcontroller expertly apportions the proper acoustics, pulse scheme, and cell size so you can focus on the measurement - not the instrument setup. The system even has a vertical beam for precise channel definition - and it's all designed to work intuitively.

Leading edge technologies such as Bluetooth<sup>®</sup>, spread spectrum radio, mobile phones, and RTK (Real-Time Kinematic) GPS are all incorporated to elevate performance and expand utility.

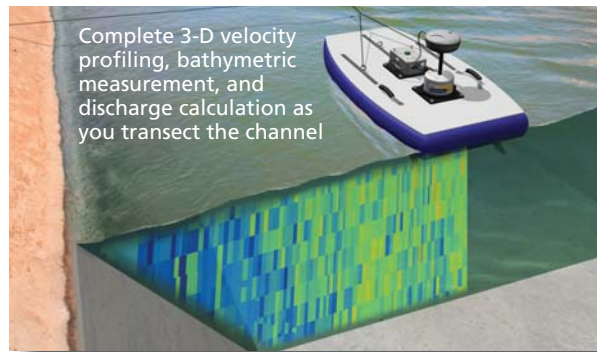
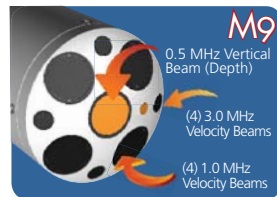

Features	Benefits
Multiple acoustic frequencies*	Combines the highest resolution with the greatest range of depths.
Vertical acoustic beam*	Superior channel definition, extends the maximum measurable discharge depth.
Automated cell size*	Always uses the optimal resolution for channel depth – no user input required.
Automated pulse scheme and frequency hopping*	Automatically adjusts the acoustic Doppler sampling (ping) scheme for channel conditions. User does not need to pre-program unit.
Microprocessor computed discharge and secure data*	All discharge computations are done within the S5 or M9 unit internally (not in the computer!) – No lost data from communications drop outs.
Standard 360° compass and two-axis tilt sensor	Compensates for vessel motion due to surface conditions.
Reverberation control with ping rates to 70Hz	High ping rates ensure extremely robust data collection.
Pulse-coherent processing	Maximizes high resolution performance in shallow water.
Bottom-tracking	High precision vessel tracking and depth measurement without GPS requirement.
RTK GPS (optional)	Ultra precise earth-referenced positioning as an alternative to bottom tracking in moving bed or other difficult situations.

\*Patents pending

## Sound Principles. Good Advice.

Display. Process. Analyze.

Exceed your expectations both during and after the measurement with RiverSurveyor Live software, a Windows XP/Vista<sup>®</sup> compatible package with the latest advancements for open channel hydraulics visualization.

- Load, view, and analyze multiple data sets simultaneously.
- Collect data and disconnect/reconnect again. Easily swap between phone and laptop mid-measurement.
- Automatic profiling set-up. Start collecting data in seconds!
- View multiple data results (bottom-track, GPS-GGA, and GPS-VTG) simultaneously.
- Quality status/data, statistics, and color coded graphical display for clear feedback in the field.
- Customizable interface, graphs, and tabular data.
- Reports & MATLAB<sup>®</sup> export.

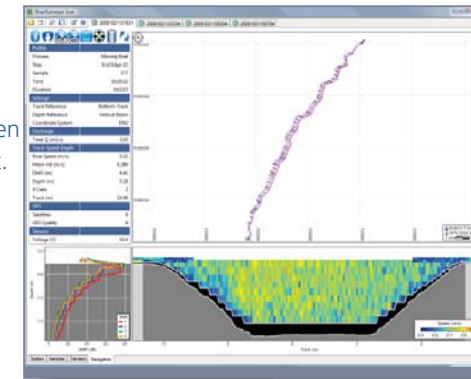

RiverSurveyor Live for PC

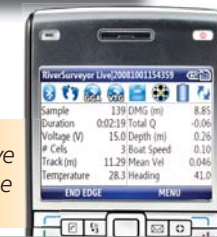

RiverSurveyor Live for Mobile Phone

### RIVERS CANALS STREAMS



River Discharge and Flow

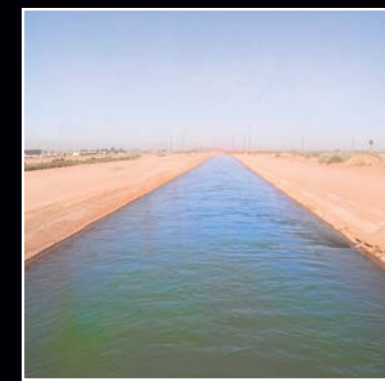

Irrigation Canals



Natural Streams



\*Hydroboard design and color subject to change.

Discharge  
Bathymetry  
Current Profiling

